

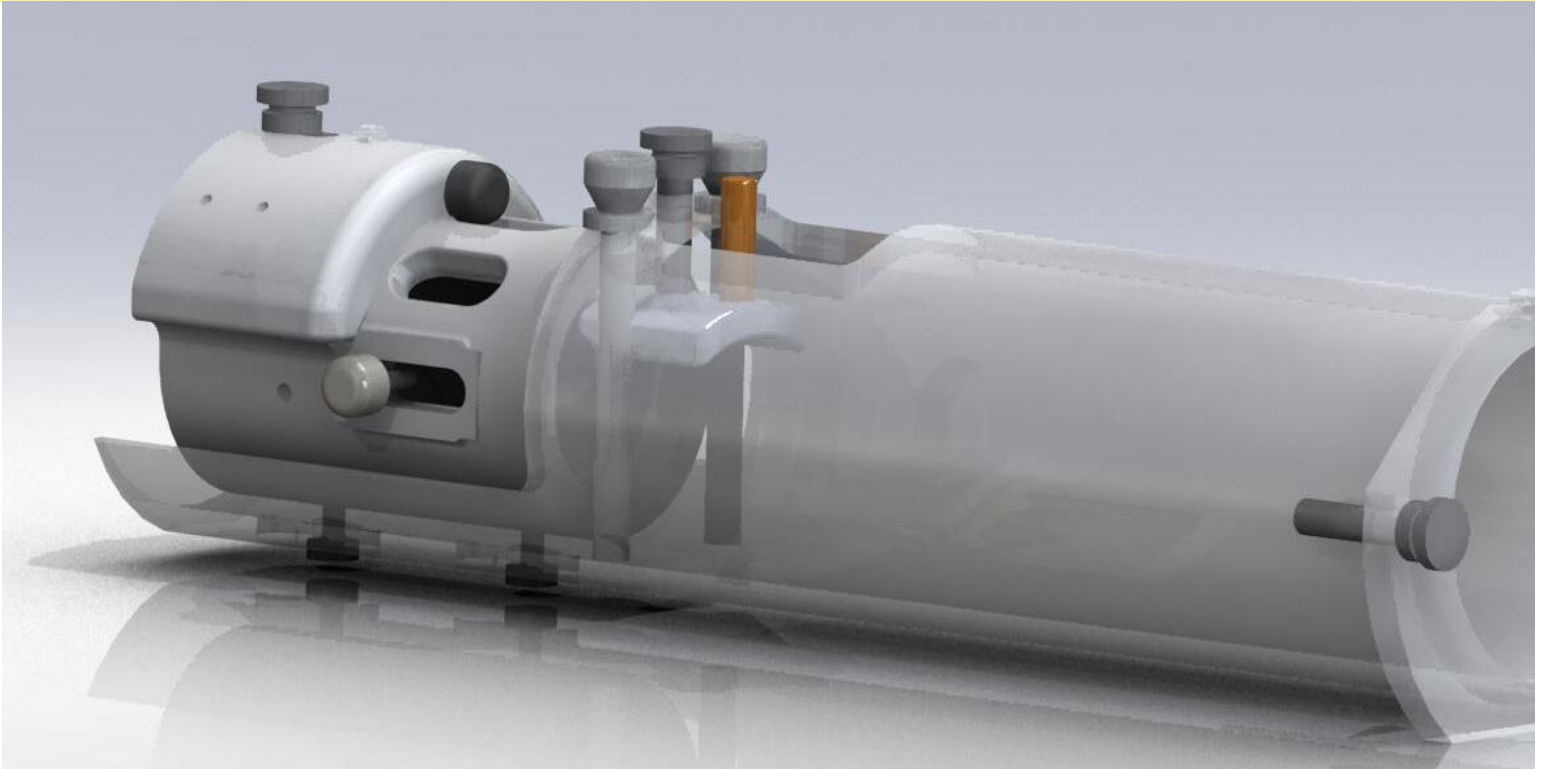

Animal Imaging Research, LLC

Quadrature Transmit/Receive Coil System for Awake or Anesthetized Rat Imaging



- Quadrature transmit/receive volume coil with exceptional SNR – no signal drop off
- B_1 field homogeneity over the entire brain
- Open design for simultaneous electrical recordings, microdialysis, optogenetics and deep brain stimulation
- 39 mm ID for optimal space filling
- Ergonomic design – animal set-up in minutes with easy tuning and matching
- Ideal for MR Spectroscopy at voxel size of 2.5 mm^3

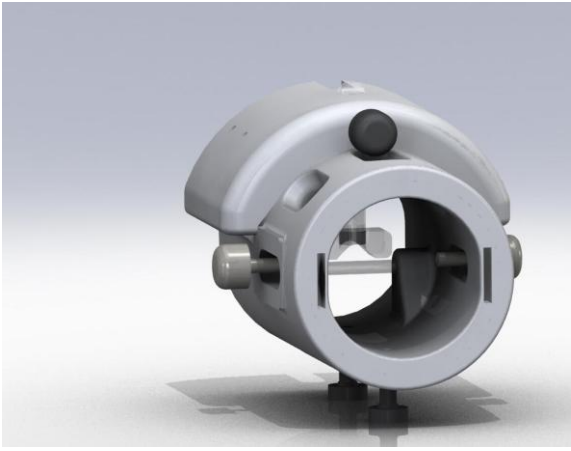

Technology at work for you

COMPLETE BRAIN COVERAGE FOR OPTIMAL RODENT IMAGING

The images below provide a sagittal view of a rat brain taken as part of a Tri-pilot. Note the linearity along the Z-axis. The three axial images from a 26-slice RARE sequence (1mm thickness) demonstrate complete brain coverage from the olfactory bulbs to the brainstem.

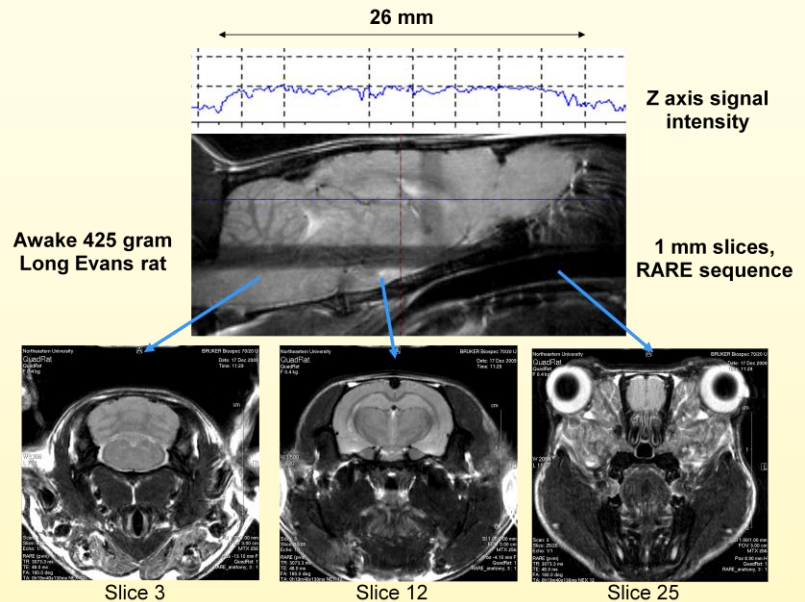

The head holder is the coil!

- Accommodates 150 to 800 gram rats - ideal for large rodent studies in aging, diabetes, obesity
- Compatible with the Bruker Animal Table and Slider System and can be easily interfaced with similar systems from Agilent and other MR equipment providers including clinical scanners
- Scalable from 1.5 to 11.7 Tesla
- Awake or anesthetized – temperature regulation for all conditions.
- The coil and holder technology have been issued four patents
- Set-up time has been reduced to minutes, allows you to better utilize your magnet time and image more animals

OPTIMAL HOMOGENEITY IN THE X & Y PLANES WITHOUT LOSS OF SIGNAL

The excellent SNR performance and field homogeneity along the X and Y axes of the AIR coil system compared to a leading surface coil is seen in the images and data below. Over the entire FOV, the AIR coil system delivers a similar SNR to the maximum surface coil SNR (see circles). The phantom is a 50cc Falcon tube filled with CuSO_4 solution.

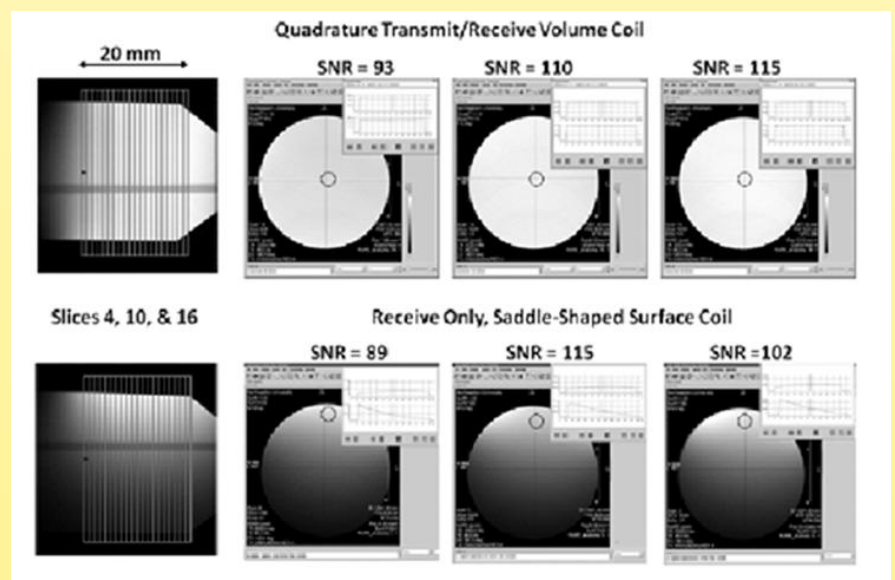

**Transforming the Image
of Brain Research**

Awake fMRI with minimal motion artifact

Shown below are screen shot images from the same rat while fully awake and also anesthetized during the same imaging session. Note the motion artifact from muscle contraction beneath the brain in the awake condition.

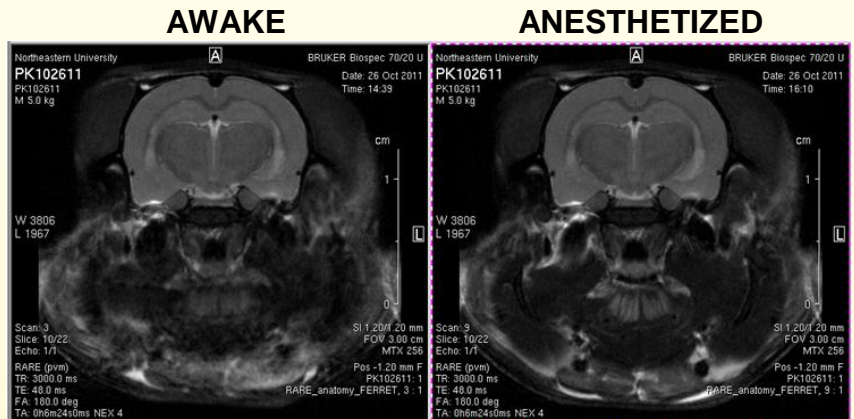

Shown below is the average ($n=5$) voxel displacement ($< 40 \mu\text{m}$) from 200 volume acquisitions in an awake rat imaged five times over a 75 min imaging session using a multislice spin echo HASTE sequence for functional connectivity studies (TR 3.1 s, TE 48 ms, 16 slices, 1mm).

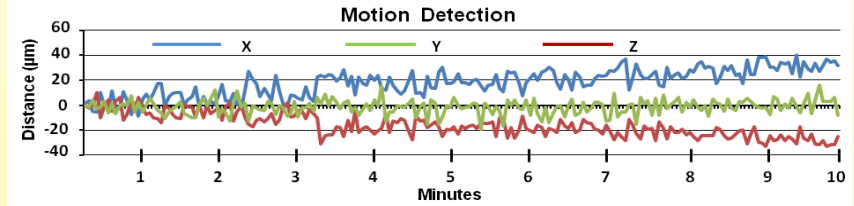

Awake MR Spectroscopy

The images below depict an H1 spectrum using a PRESS sequence (water line 8 Hz) with 512 averages. Shown are two adjacent sections (each 1.2 mm thick) in the forebrain of an awake adult rat. The voxel (outlined box) measuring 2.5 mm^3 is positioned over the caudate/putamen.

The report below is a standard Bruker report, generated from its internal analysis software – showing coil performance using the Bruker phantom with the AIR imaging system mounted on the Bruker Animal Table and Slider System. Note the Total-Image SNR/ mm^3 in the column at the bottom right (in red).

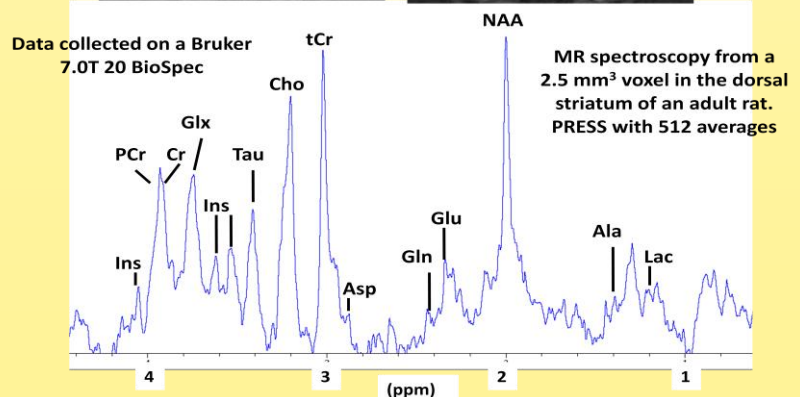
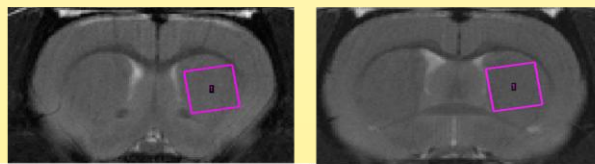

PROVEN TECHNOLOGY

AIR's engineering team works with a complete set of proprietary, high-performance coil analysis and design tools. This enables AIR to design, simulate, and optimize its products on standard computer platforms using available, proven technology.

OPTIMIZED DESIGN FOR CUSTOM PROJECTS

The common denominator underlying AIR's imaging systems is our software design portfolio that integrates electronics with mechanics. We utilize 3-D and prototype coil modeling, magnetic field mapping, and advanced MR gradient and RF coil simulation tools for both our standard and custom coils with Solid Works. As system performance is highly dependent on coil size, filling factor and immobilization of the animal for awake imaging, AIR harmoniously integrates coil design into mechanical restraining system to optimize performance and minimize conflicts between design requirements. We have extensive experience designing small bore imaging systems for mice, voles, rats, rabbits and small and large non-human primates.

QUALITY CONSTRUCTION

Component and sub-assembly manufacturing is either outsourced to highly capable companies in close proximity to AIR or performed in-house. Materials used in MRI components often have unique properties and as such, AIR utilizes its own CNC machining equipment and lathes where final processing is performed. All assembly and calibration testing takes place in a controlled production area at the AIR's location.

Compatible with Bruker and other MR systems

The Transmit/Receive Coil System has been designed with a compatible interface to the Bruker Animal Table and Slider System – as shown in the picture below. Similar interfaces can be constructed for Agilent and other MR equipment providers.

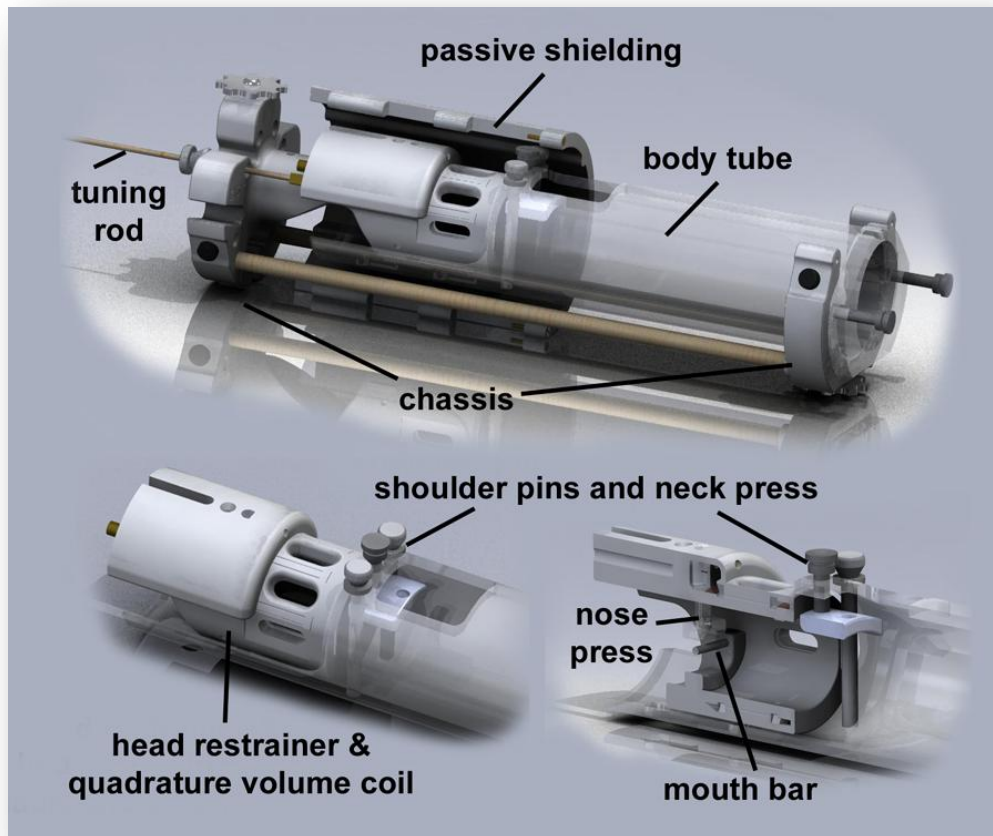

Animal Imaging Research LLC

To learn more about how awake animal imaging and AIR's coil systems can enhance your CNS research programs, contact us at:

Animal Imaging Research, LLC
P.O. Box 175
Holden, Massachusetts 01520-0175
Phone: 978-668-5078
Info@airmri.com
[www:animalimagingresearch.com](http://www.animalimagingresearch.com)